

# 10 Watt Recessed Halogen (Keepalite)

*Complete with 1.5m Flex and Plug*



The Bardic Keepalite is designed for situations where emergency evacuation lighting is to be unobtrusive and aesthetic but effective. The luminaire disc is of a slim concave construction. Available in two diameter options the control circuitry and battery are mounted in a separate container for remote mounting.

## Features

- Designed and tested to comply with AS/NZS 2293
- Easy to install - Spring clip disc mounting
- Automatic battery low voltage cut-out to prevent over discharge of the battery
- Available with Sealed Lead Acid or Nicad Batteries
- High temperature components for extended life
- Red L.E.D. indicates a healthy A.C. mains supply and functioning charger
- Test switch to test the emergency operation while A.C. mains is healthy
- Entire wiring loom simply unplugs. Separating disc from control enclosure.

# 10 WATT RECESSED HALOGEN SPECIFICATIONS

	BC10S BC10S-85	BC10NS BC10NS-85	10SC110	10SC240AC
Function	Non Maintained	Non Maintained	Non Maintained Slave	Non Maintained Slave
Battery	Lead Acid	High temp Nicad	Not Applicable	
Emergency duration after a 16 Hour recharge on Commissioning	2 Hour Minimum	2 Hour Minimum		
Power Consumption (Maximum)	10VA		16VA	12VA
Input Voltage	240VAC		110VDC	240VAC
Frequency	50Hz		Not Applicable	50Hz
Environment	INDOOR			
Standards	AS/NZS 2293			
Control Body Construction	Sheet Steel - White		Plastic - Black	
Disc Construction	Sheet Steel - White			
IP Classification	IP21			
Charger	Constant Voltage	Dual Rate	Not Applicable	
Sentinel Compatible	Yes		No	
Weight	2.5kg	2.5kg	0.45kg	0.90kg
Control Body	- 'Length'	377mm		120mm
	- 'Width'	112mm		84mm
	- 'Depth'	51mm		60mm
Disc Diameter	142mm diameter standard. Also available with 85mm dia. model identified with the suffix -85.			
Disc Depth	25mm			
Ceiling Cut-Out 142mm Disc	122mm minimum			
Ceiling Cut-Out 85mm Disc	75mm minimum			

**AUSTRALIA**  
**Head Office:**  
 9 Mosrael Place  
 Rowville Victoria 3178  
 Telephone: (61 3) 9763 0555  
 Facsimile: 1300 733 005

**New South Wales:**  
 Unit 21/14 Stanton Road  
 Seven Hills NSW 2147  
 Telephone: (61 2) 9674 3199  
 Facsimile: 1300 733 005

**Queensland:**  
 12 The Corso  
 Seven Hills QLD 4170  
 Telephone: (61 7) 3902 0902  
 Facsimile: 1300 733 005

**South Australia:**  
 89A Grange Road  
 Allenby Gardens SA 5009  
 Telephone: (61 8) 8340 4081  
 Facsimile: 1300 733 005

**Western Australia:**  
 B-Type Agencies Pty Ltd  
 Unit 2/15 Narloo Street  
 Malaga WA 6090 Perth  
 Telephone: (61 8) 9209 2220  
 Facsimile: (61 8) 9209 2229  
 Email: Infor@btype.com.au

**Tasmania**  
 Cables Plus (Tas) Pty Ltd  
 8 Devon Street  
 South Bernie TAS 7320  
 Telephone: (61 3) 6431 8660  
 Facsimile: (61 3) 6431 4430

**NEW ZEALAND**  
**Auckland**  
 Unit B 237 Bush Road  
 Albany, Auckland  
 Telephone: (649) 415 6615  
 Facsimile: (649) 415 8160

**Wellington**  
 Unit 7 30-32 Downer Street  
 Lower Hutt, Wellington  
 Telephone: (644) 586 6188  
 Facsimile: (644) 586 6088

**Christchurch**  
 8 Kirkdale Place  
 Avonhead, Christchurch  
 Telephone: (643) 358 8444  
 Facsimile: (643) 358 8446

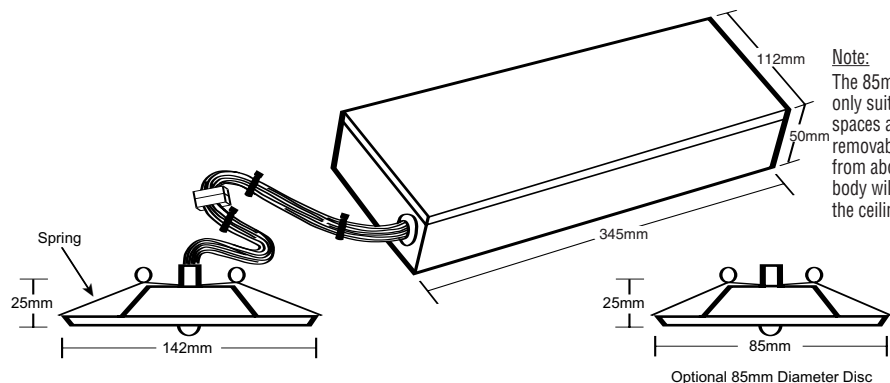

**Note:**  
 The 85mm disc is only suitable for ceiling spaces accessible via removable tiles or from above. The control body will not fit through the ceiling cut-out.

**Note:**  
 Design and/or specifications subject to change without notice.



ABN 9605 1792 833